

ATLAS with CARIBU: A Laboratory Portrait

Introduction and Evolution of ATLAS

The Argonne Tandem Linac Accelerator System (ATLAS) is the world's first superconducting accelerator for projectiles heavier than the electron. This unique system is a U.S. Department of Energy (DOE) national user research facility open to scientists from all over the world. It is located within the Physics Division at Argonne National Laboratory and is one of five large scientific user facilities located at the laboratory.

ATLAS began as a proof-of-principle project in the early 1970s to demonstrate that a superconducting resonator's field amplitude and phase could be controlled with sufficient precision to enable the acceleration of ions. The first demonstration of such

heavy-ion acceleration was accomplished in 1978 and in 1985 ATLAS [1] was identified as a U.S. national user facility for low-energy nuclear physics research. In the 30 years since, the field has moved significantly with regard to the demands for the types of beams required to address its current research topics. In order to continue to meet these evolving requirements, ATLAS has been continuously upgraded to provide the tools necessary to remain at the forefront of nuclear science.

The facility serves a national and international user community of more than 500 registered members. ATLAS is maintained and operated by a staff of roughly 25 technicians, engineers, and scientists and a similar sized group provides support for the experimen-

tal program. On average between 40 and 50 experiments take place every year. Roughly 300–400 users come to the facility yearly to carry out their measurements. The facility operates around the clock, 7 days/week and typically provides 5,500–6,000 hours of operation for research per year.

Today, ATLAS consists of three superconducting linac sections: the Positive Ion Injector, the Booster, and the ATLAS linacs. Together, they can provide over 50 MV of accelerating voltage for all stable ions from protons through uranium. Recently, the array of beams available was expanded, by the CARIBU [2] project, and now includes neutron-rich, short-lived nuclei produced in the spontaneous fission of ^{252}Cf . In addition, near-to-stability light radioactive ions are available

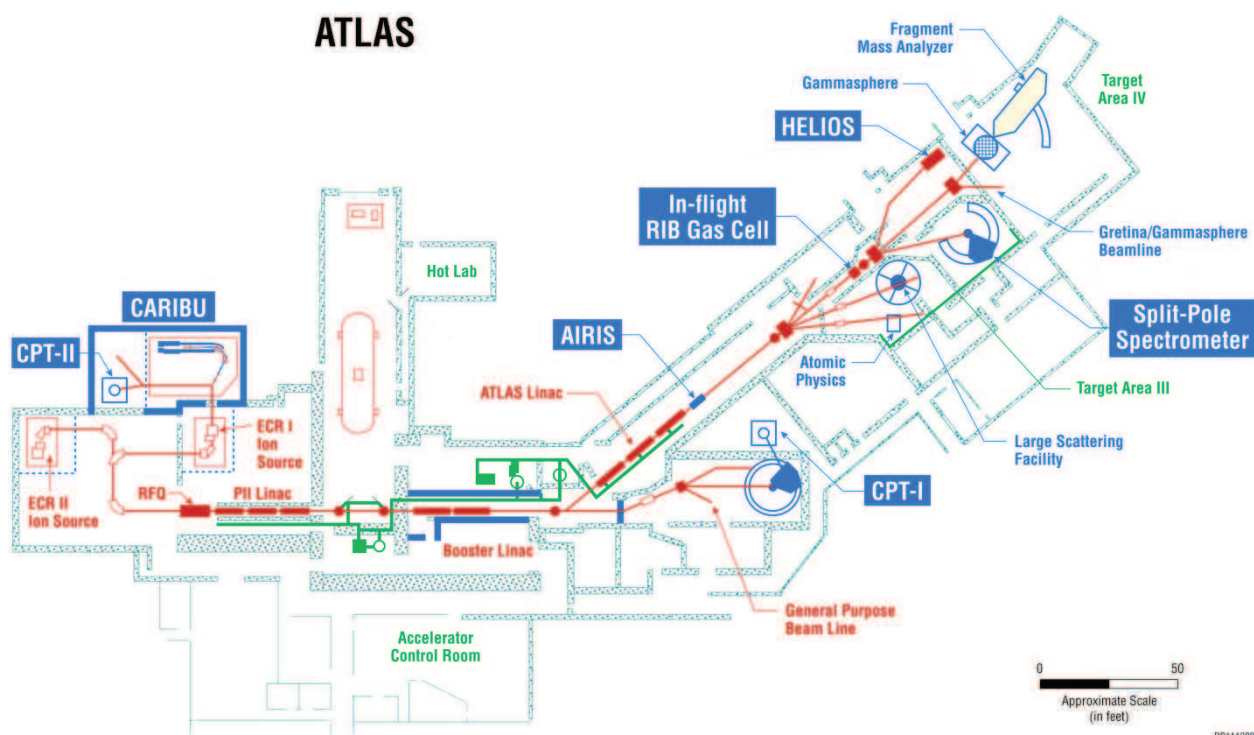

Figure 1. Floor plan of ATLAS facility with the major components of the accelerator and the major experimental equipment identified.

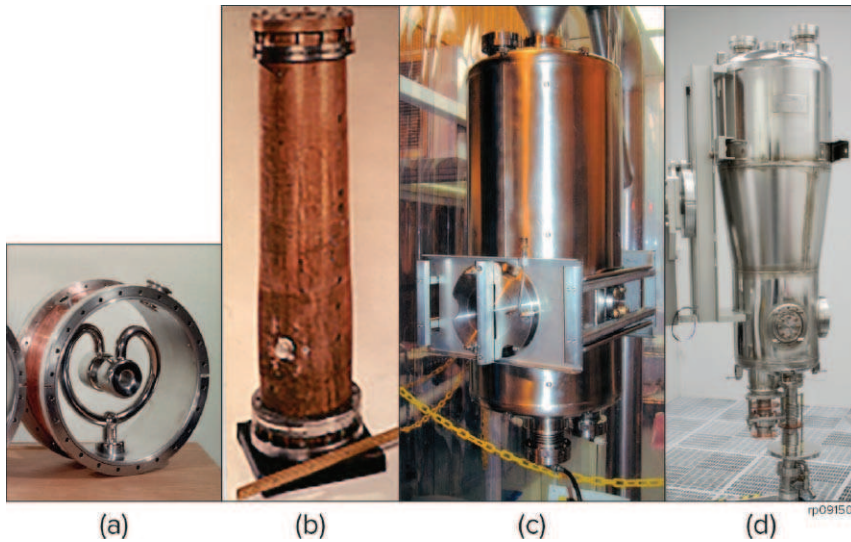

Figure 2. The photos from left to right illustrate the evolution of resonator technology developed at ATLAS: (a) the split-ring resonator first used at ATLAS, followed by various quarter-wave resonator designs used for the Positive Ion Injector in the 1990s (b), a new high-beta ($\beta = 0.13$) design from 2008 (c), and the most recent ($\beta = 0.07$) resonator design of 2014 (d).

via an in-flight production technique [3] using charge exchange or few nucleon transfer reactions with stable ion beams on a gas or foil target. The floor plan of the present ATLAS facility is shown in Figure 1.

The heart of ATLAS is the superconducting resonator (Figure 2). The first successful test of a niobium splitting resonator occurred in November 1977. A key component in the continuing success of ATLAS has been constant improvements to the facility including the evolution of best practices in constructing and operating superconducting resonators. Those developments are seen in the different classes of resonators that have been developed at Argonne and the new techniques in superconducting RF (SRF) technology that have been applied. From the split-ring resonator, which was capable of approximately 3 MV/m accelerating field to the quarter-wave resonators used in the Positive Ion Injector section of ATLAS [4] installed in the early 1990s; and now

to the fully helium immersed, pure niobium quarter-wave resonators used in an energy upgrade [5] of the facility in 2009 as well as the most recent new upgrade [6] to the center (Booster) section of ATLAS in 2014, one sees a continuing progression of state-of-the-art SRF technology now culminating in routine accelerating fields of about 9 MV/m.

In the last six years, the ATLAS accelerator has undergone a number of improvements that are aimed at addressing the current and future needs of the nuclear science community. In addition to the CARIBU project described below, which has opened a completely new class of ion species for research, three major changes to the ATLAS accelerator have provided significant performance improvements in both accelerating fields and beam transmission:

1. A new cryostat of six quarter-wave ($\beta = 0.13$) resonators has been installed as the last ATLAS

cryostat raising the maximum beam energy to approximately 21 MeV/u for the lightest ions.

2. A new, room-temperature CW radio frequency quadrupole (RFQ) linac [7] has been installed as the first accelerating resonator in the linac. It replaces three of the original, very low-velocity, superconducting resonators of the Positive Ion Injector (PII) Linac. This project has improved the overall bunching efficiency so that approximately 80% of the DC source current can be captured into a high-quality beam for acceleration through ATLAS.
3. A second new cryostat of seven quarter-wave ($\beta = 0.07$) resonators has replaced three cryostats of split-ring resonators in the middle section (booster) of the ATLAS linac. These resonators are achieving world-record accelerating field performance for low-beta resonators, thereby reducing the total resonator count in the linac (from 65 to 51) while maintaining the total accelerating voltage.

It should be noted that the original injector accelerator for ATLAS—the FN tandem electrostatic accelerator—has now been retired, and the facility only has two electron cyclotron resonance (ECR) sources as injectors at the present time (Figure 1). The improvement in performance resulting from these upgrades now enables the total beam delivery to often reach 70% from the ion source to the target compared to 30–40% common in the older configuration. This improved transmission is critical for the delivery of the weak-intensity radioactive beams from CARIBU and for the maximum beam intensity available for experiments requiring high currents of stable beams,

such as the in-flight RIB program, for example.

The CARIBU Project

In 2005, it was proposed to increase the radioactive beam capabilities of ATLAS by the installation of a new source of ions to provide beams of short-lived, neutron-rich isotopes. This is the Californium Rare Ion Breeder Upgrade (CARIBU) project (<http://www.phy.anl.gov/atlas/caribu/index.html>). This upgrade enhances the reach of ATLAS into neutron-rich nuclei and offers world-unique capabilities for study in (N,Z) regions largely unreachable to date. In CARIBU, the neutron-rich isotopes are obtained from an approximately 1 Curie (Ci) ^{252}Cf fission source located in a large gas catcher filled with high-purity helium which rapidly thermalizes and transports the fission fragments to a RFQ cooler. This arrangement transforms approximately 50% of the fission fragments emitted from the source into a beam of 1^+ (or 2^+) ions with very low transverse emittance and energy spread. The beam from the gas catcher is then accelerated to 30–50 keV and mass analyzed by a high-resolution (1 part in 20,000) isobar separator. The selected ion species is finally sent either to a low-energy experimental area for measurements using a multi-reflection time-of-flight spectrometer (MRTOF) to further purify the beam, or to an ECR ion source modified for charge breeding prior to subsequent acceleration into ATLAS. The source and gas cooler system are installed on a high-voltage platform that allows the ions to gain sufficient velocity for injection into the ATLAS linac and acceleration to energies up to ~ 15 MeV/u. The ion extraction and beam formation steps at CARIBU are efficient and fast, 20–30 ms from fission to mass separation, for all spe-

cies independently of their chemical properties. As a result, the distribution of ions available from CARIBU is essentially determined by the ^{252}Cf fission branches. Figure 3 shows the extracted low-energy isotope distribution expected for CARIBU operating with a thin 1 Ci fission source. The ^{252}Cf source for CARIBU must have high activity yet be thin enough to minimize self-absorption of the recoils in the source. Such a source has not yet been available for CARIBU, but the physics program has started with a very intense (initially 1.7 Ci), but very thick source that is effectively equivalent to a 70 mCi thin source for fission recoils. Therefore, the intensity of these beams is currently roughly an order of magnitude below that expected with a thin source, but the universally fast and efficient extraction for even the most refractory species is confirmed and allows CARIBU to deliver world-unique reaccelerated beams to its users. The overall CARIBU facility layout is found in Figure 4 and a picture of the CARIBU high-voltage platform is shown on the cover.

The individual isotopes are extracted from CARIBU as a 30 to 50 keV continuous beam. Experiments at low energies do, however, rely more and more on ion-trapping techniques, which have specific requirements for an efficient capture of the ions, namely pulsed beams at very low energy of a few keV. The low-energy beam-line configuration, in Figure 4, consists of an RFQ ion buncher used to accumulate the ions, followed by an electrostatic elevator where the energy of the beam is adapted to the experimental requirements, followed by a low-energy switch yard to distribute the ions of interest to various experiments. For typical measurements, the beam is accumulated and cooled for 50 to 100 ms after which it is extracted as a few μs long ion bunch. By changing the

small acceleration potential or the potential to which the elevator electrode is pulsed, ion beams with repetition rates of 1 to 20 Hz can be obtained at variable energies ≤ 10 keV, depending on the needs of the particular experiment. These beams then pass through two electrostatic switchyards that can feed a total of five experimental stations.

For nuclear reaction studies, the ions must be accelerated in the ATLAS linac. Since 1^+ or 2^+ ions emerge from the gas catcher system, the charge state needs to be increased so that the mass-over-charge (m/q) ratio for accelerated ions is ≤ 7 , the ATLAS acceptance. As shown in Figure 4, until recently, this has been accomplished with an ECR ion source. The CARIBU charge breeder (ECRB) is a 10 GHz ECR ion source modified to allow multiple-frequency plasma heating, and significantly redesigned on the rear (injection) side to accept beams from CARIBU into the ECR plasma. The ions are stopped in this plasma, charge-bred and extracted in the required charge state for subsequent acceleration by ATLAS. The ECRB source has demonstrated the highest yields into a single charge ever obtained in charge breeding with a source of this type. The typical efficiency into one charge state obtained in a variety of runs with both stable and radioactive ions is approximately 10% and the best performance for CARIBU beams has been 15% [8].

Early in the development of the ECRB charge breeder, it was realized that background beams from various impurities in the system could pose a problem with the delivery of very weak, radioactive beam species. This continues to be a major issue for ECR sources [8]. The inherent scrubbing action of the plasma on the walls of the vacuum chamber and other source components creates a background of

stable beam species which can have the same m/q ratio as the radioactive beam of interest. Once such contaminant species are in the plasma, they are very difficult to reject. To improve the beam purity, an Electron Beam Ion Source (EBIS) has been developed. The ions in an EBIS do not have wall interactions and, thus, the EBIS-bred beams generally have much higher purity as well as a somewhat better efficiency into the peak charge state. The EBIS operates best in a pulsed mode with a time period of the order of 10–100 ms and so requires a much more complex beam preparation system than is the case for the ECR charge breeder. Still, a factor of roughly 2 increase in breeding efficiency is expected when compared to the ECRB source, while achieving a much lower background of stable ions. The ATLAS EBIS source [9] has now been commissioned off-line and installation at CARIBU is under-

way. Commissioning with a CARIBU beam is planned for April 2016.

CARIBU is now fully operational and its low-energy and reaccelerated beams have been used in a number of physics campaigns over the last few years. The main instrument in the low-energy experimental area is the Canadian Penning Trap mass spectrometer which has been used to measure to high accuracy the mass of over 150 of the close to 500 neutron-rich isotopes available at the facility. This program aims at a better determination of the key nuclear inputs to r -process calculations. It is supplemented by decay spectroscopy measurements and beta-delayed neutron measurements. The CARIBU reaccelerated beam program takes advantage of the suite of instruments available at ATLAS. For the last year, ATLAS has hosted GRETINA, the national gamma-ray tracking array. As a result, the program with reaccelerated CARIBU beams has mostly

focused on Coulomb excitation measurements on nuclei located near the two peaks in the distribution of fission fragments (Figure 3). Thus, this part of the ATLAS research program focused on the onset of collectivity near $A = 100$, the search for evidence of triaxiality in neutron-rich Zr, Mo, and Ru nuclei, and the determination of octupole strength in the Ba – La – Ce region. The combination of the unique CARIBU beams, at the optimum energy for multi-step Coulomb excitation, with the exquisite Doppler reconstruction of GRETINA proved ideal for this campaign.

While the beam intensity currently available at CARIBU is sufficient for a low-energy program over a wide range of isotopes and for reaccelerated beam experiments with beams close to the peak in the production, a broader reaccelerated beam program requires both higher intensity to extend the measurements to a wider range of

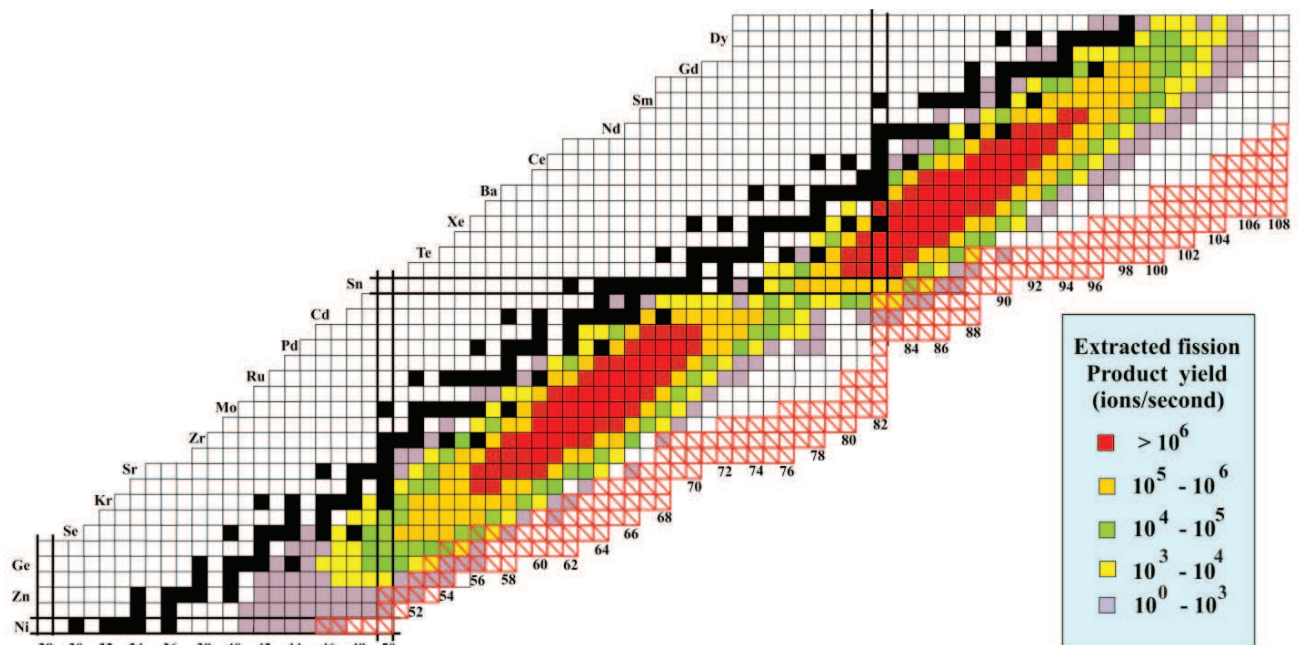

Figure 3. Distribution of isotopes available from the 3% fission branch of ^{252}Cf . The color legend provides the yields expected from a thin 1 Ci source exhibiting the wide distribution of neutron-rich isotopes characteristic of fission. Also shown in marked red squares are the isotopes thought to be located along a typical r -process path.

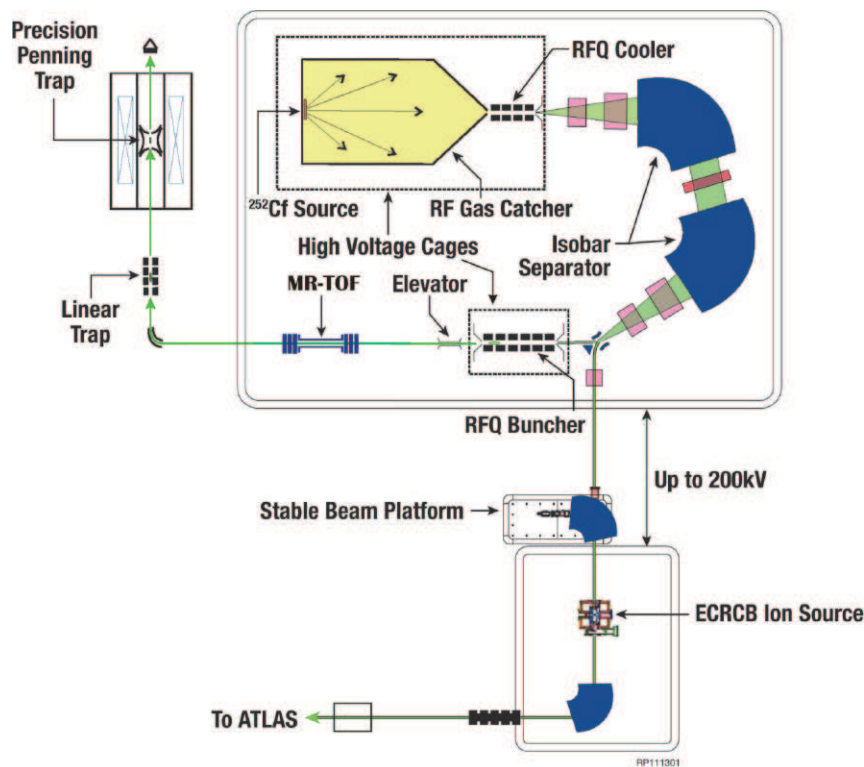

Figure 4. Floor plan of the CARIBU facility at ATLAS. The individual components are discussed in the text. The unlabeled boxes before and after the isobar separator represent quadrupole and sextupole magnets. The box between the two magnets represents an electrostatic multipole.

isotopes and improved beam purity to perform experiments which must detect beam-like particles at zero degree. This is being addressed with the new EBIS charge breeder that will come in operation in early 2016 and with the installation of a new, thinner ^{252}Cf source that is expected on a similar time scale. This will allow for not only an extension of the ongoing programs but also for the start of new programs such as transfer reaction measurements in the region near ^{132}Sn .

In-Flight RIB Capability at ATLAS: Present and Future

In many nuclear physics laboratories around the world, there has recently been an increased interest in experiments with light, short-lived radioactive nuclei. At ATLAS, prior

to the CARIBU facility, experiments with radioactive beams have been performed for about two decades with such short-lived nuclei. For this purpose, the ATLAS accelerator pro-

vides a high-intensity stable beam accelerated onto a production target at an energy suitable to produce the radioactive species of interest through charge exchange or few nucleon transfer reactions. The reaction products are collected and separated from the un-reacted primary beam before being used for experiments. This “in-flight” production method gives access to more than 100 short-lived isotopes in the mass range up to $A \sim 60$. Over the years, this technique has been refined by making use of the unique time structure of the ATLAS accelerator to improve the energy resolution and the purity of the secondary beams. For example, to produce the short-lived isotope ^{17}F (half-life 1.08 m), a primary ^{16}O beam impinges on a gas cell containing deuterium. A beam intensity of 2×10^6 $^{17}\text{F}/\text{s}$ was produced by the $d(^{16}\text{O}, ^{17}\text{F})n$ reaction with a 100 pA primary beam of ^{16}O in a way schematically depicted in Figure 5.

Because of the kinematics of the reaction, the ^{17}F ions of interest exit the cell in a narrow forward cone. They are then focused and collected into a beam by a 4 T superconducting solenoid, before passing through a superconducting RF cavity employed in a so-called de-bunching mode to reduce the energy spread of the ra-

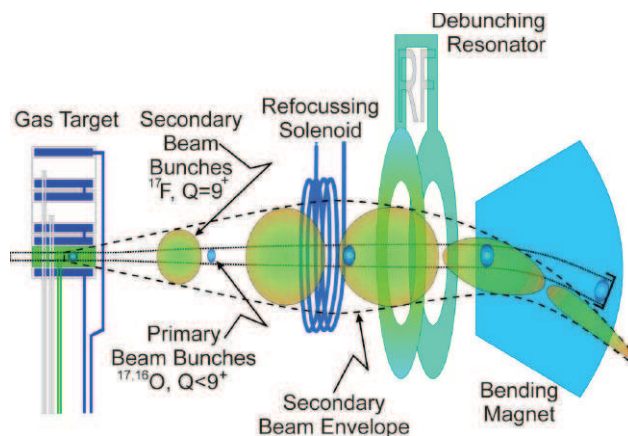

Figure 5. Principle of the in-flight technique for the production of radioactive beams.

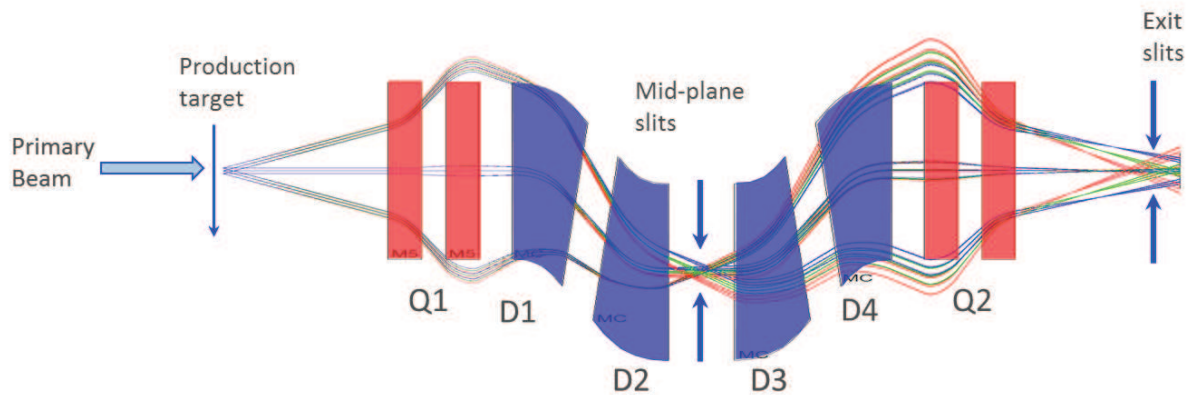

Figure 6. A schematic of the magnetic chicane now under construction for the new AIRIS in-flight facility.

radioactive beam. A bending magnet then separates the ^{17}F ions from the remaining ^{16}O primary beam before it hits the target where the experiment takes place. Recently, a RF beam sweeper has been added to the system in order to remove the tail components of the primary beam which have the same magnetic rigidity as the radioactive beam of interest. Additional information on the technique and a list of beams produced in this manner is available at http://www.phy.anl.gov/atlas/facility/radioactive_beams.html.

In order to increase the in-flight RIB beam intensity and to expand the range of nuclei that can be studied via direct reactions, a new project to build a dedicated in-flight production target and a recoil separator downstream of the last accelerator cryostat has been initiated. The Argonne In-flight Radioactive Ion Separator (AIRIS) [10] will be able to take advantage of the higher primary beam intensity and beam energy that is available as a result of the recent accelerator upgrades. The future location of AIRIS is indi-

cated in Figure 1. The modeled design of the AIRIS separator (Figure 6) consists of a focusing quadrupole doublet magnet Q1, located immediately after the production target, followed by two dipoles, D1 and D2, which bend the particles in opposite directions. This arrangement focuses the reaction products and the primary beam onto the mid-plane of the separator where the desired radioactive beam component can be selected by a slit arrangement. The second half of the separator mirrors the upstream components.

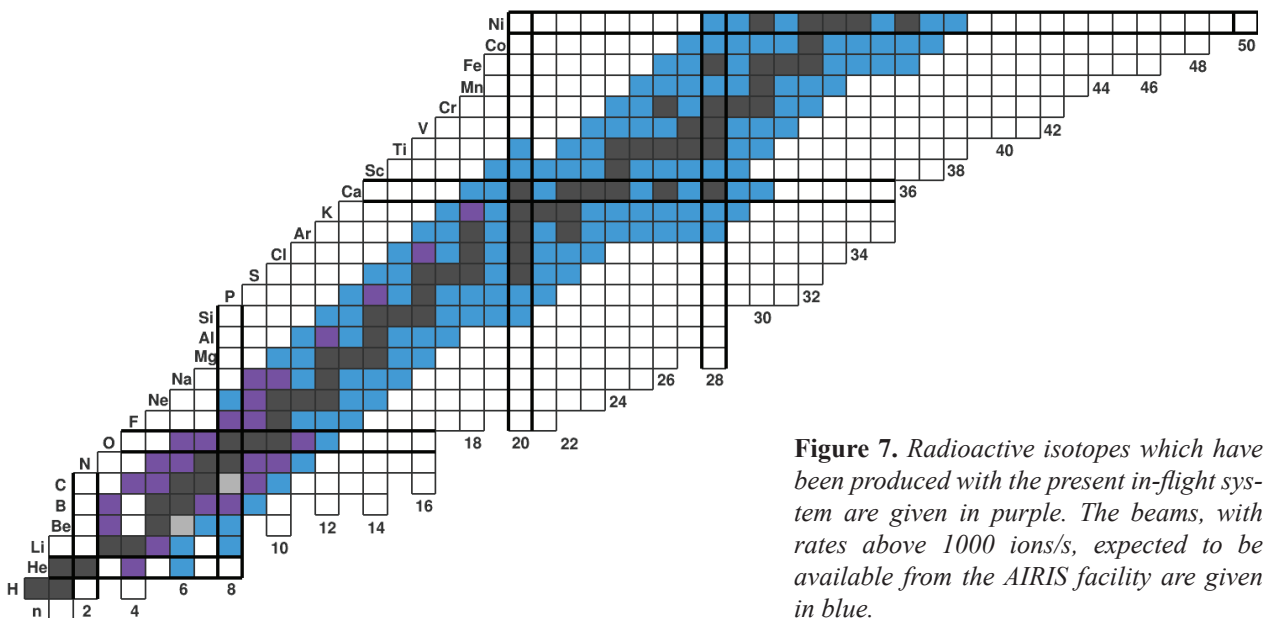

Figure 7. Radioactive isotopes which have been produced with the present in-flight system are given in purple. The beams, with rates above 1000 ions/s, expected to be available from the AIRIS facility are given in blue.

The intrinsic kinematic energy spread of the radioactive beam can be partly eliminated by using superconducting de-bunching cavities further downstream of the target and AIRIS chicane. In addition, the RF sweeper mentioned above will be relocated onto the main beam-line to further improve the purity of the radioactive beams by removing primary beam tail components. An additional benefit of AIRIS compared to the previous in-flight system is that its location on the main beam-line after the last ATLAS resonator will allow these beams to be available at all targets stations past this point.

For production reactions such as (d,p) neutron-transfer for example, a liquid-film target using deuterated vacuum pump oil is being developed. This target employs the technology pioneered at Argonne to provide liquid lithium strippers for the Facility for Radioactive Ion Beams (FRIB) that is presently being built at Michigan State University. For radioactive beams that are best produced with solid targets, such as ^{12}C and ^9Be , the standard technology of a fast-rotating target wheel will be employed. The beams that are expected to be available from the AIRIS system are given in Figure 7.

Summary

ATLAS pioneered the use of superconducting RF (SRF) for low velocity beams over 35 years ago and its development team continues to play leading roles in SRF accelerator R&D and in associated technologies. Uses of these technologies are now widespread in accelerator facilities around the world. The ATLAS team continues to develop new techniques to address the current research goals of the nuclear science community, as demonstrated with the CARIBU, and accelerator upgrade projects that have just recently

been completed as well as with ongoing construction projects such as the EBIS charge breeder and the AIRIS in-flight separator.

Acknowledgments

The work at ATLAS is supported by the U.S. Department of Energy Office of Science, Office of Nuclear Physics, under Contract No. DE-AC02-06CH11357. This research used resources of ANL's ATLAS facility, a DOE Office of Science User Facility.

References

1. L. M. Bollinger, R. C. Pardo, K. W. Shepard, et al., *Nucl. Instrum. Methods Phys. Res.* B79 (1993) 753.
2. G. Savard, A. Levand, R. Pardo, et al., Proceedings of the 2nd Conference on Advances in Radioactive Isotope Science (ARIS2014), Tokyo, Japan, 1–16 June, 2014; *JPS Conf. Proc.* 6 (2015) 010008/1-7.
3. B. Harss, R. C. Pardo, K. E. Rehm, et al., Proceedings of the 8th International Conference on Ion Sources, Kyoto, Japan, 6–10 September 1999; *Rev. Sci. Instrum.* 71 (2000) 380.
4. L. M. Bollinger, R. C. Pardo, K. W. Shepard, et al. Proceedings of the 12th International Conference on the Application of Accelerators in Research and Industry, Denton, TX, 2–5 November 1992; *Nucl. Instrum. Meth.* B79 (1993) 753.
5. P. N. Ostroumov, J. D. Fuerst, S. Gerbick, et al., Proceedings of the 23rd Particle Accelerator Conference (PAC09), Vancouver, BC, Canada, 4–8 May 2009, FR5REP045 (2010) 4869.
6. M. P. Kelly, Z. A. Conway, S. M. Gerbick, et al. 27th Linear Accelerator Conference (LINAC14), Geneva, Switzerland, 31 August–5 September 2014.
7. P. N. Ostroumov, B. Mustapha, A. Barcikowski, et al., *Phys. Rev. ST Accel. Beams* 15, 110101. 14 November 2012
8. Richard Vondrasek, A. Barcikowski, C. A. Dickerson, et al., 13th International Conference on Heavy Ion Accelerator Technology (HIAT2015), Yokohama, Japan, 7–11 September 2011, to be published in JACoW conference proceedings.
9. P. N. Ostroumov, A. Barcikowski, C. A. Dickerson, et al., 16th International Conference on Ion Sources (ICIS15), New York, NY, 23–28 August 2015, to be published in *Rev. Sci. Inst.*, 87 (2016) 02B506.
10. B. Mustapha, M. Alcorta, B. Back, and P.N. Ostroumov, Proceedings of the Particle Accelerator Conference, MOPSM02, <http://accelconf.web.cern.ch/AccelConf/PAC2013/papers/mopsm02.pdf>



RICHARD C. PARDO
*Physics Division, Argonne National
Laboratory, Argonne, Illinois, USA*



GUY SAVARD
*Physics Division, Argonne National
Laboratory, Argonne, Illinois, USA*



ROBERT V. F. JANSSENS
*Physics Division, Argonne National
Laboratory, Argonne, Illinois, USA*